

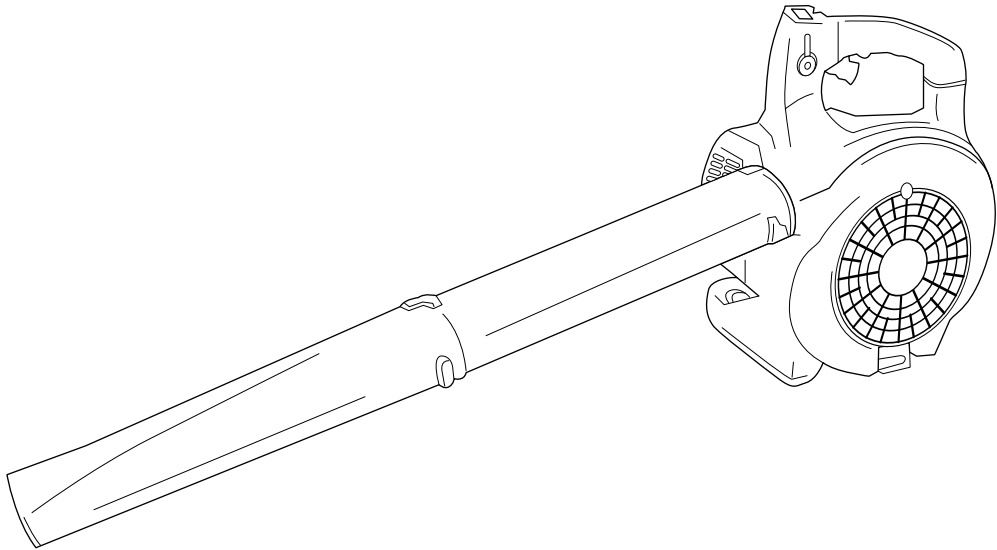

BL3210



Owner's/Operator's Manual

Completely read and understand this manual before using this product.



FOREWORD

This Owner's/Operator's Manual is designed to familiarize the operator with the various features and component parts of the equipment and to assist you with the assembly, operation and maintenance of your new Hand-held Blower.

It is essential that any operator of this Hand-held Blower product reads and understands the contents of this manual before using the Hand-held Blower.

Important safety instructions will be identified by the following safety symbol:



Failure to comply with the instructions in this manual may result in serious injury or death. For additional assistance, contact any local authorized Maruyama dealer.

TABLE OF CONTENTS

Foreword.....	1	Starting and stopping procedure	10
Specifications	1	Carburetor adjustment.....	12
Product description.....	2	Operating the Hand-held Blower	13
Marking.....	3	Regular maintenance	13
Symbol Explanation.....	3	Storage	18
Safety instructions	4	Troubleshooting	19
Assembly	7	Maintenance period.....	19
Before operation	8		

SPECIFICATIONS

Models	BL3210
Length x Width x Height 1	325 x 255 x 370mm
Dry Weight 1	4.4 kg
Engine Displacement	30.1cm ³
Fuel Tank Capacity	0.5 ℓ
Carburetor	Walbro Diaphragm Type
Ignition System	Solid State
Spark Plug:	
Make	NGK
Type	BPMR6Y
Electrode Gap	0.6 ~ 0.7mm
Starter	Reverse2 Start
Fuel Mixture:	Use only non-leaded regular gasoline. 2-Cycle oil mix 25:1 ratio must be approved for air-cooled engines.
Sound Pressure Level (Max. rpm)	80dB(A)
Vibration Level Handle (Max. rpm)	13m/s ²
Maximum Air Volume	13m ³ /min

1. Dry weight without Pipe A and B

PRODUCT DESCRIPTION

MODEL:BL3210

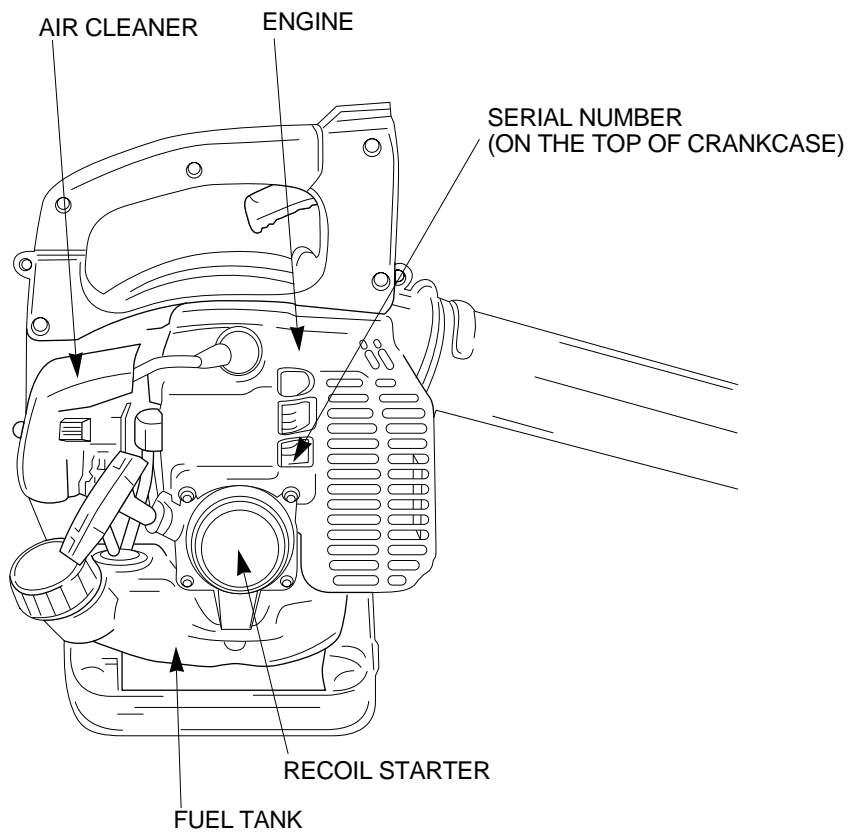
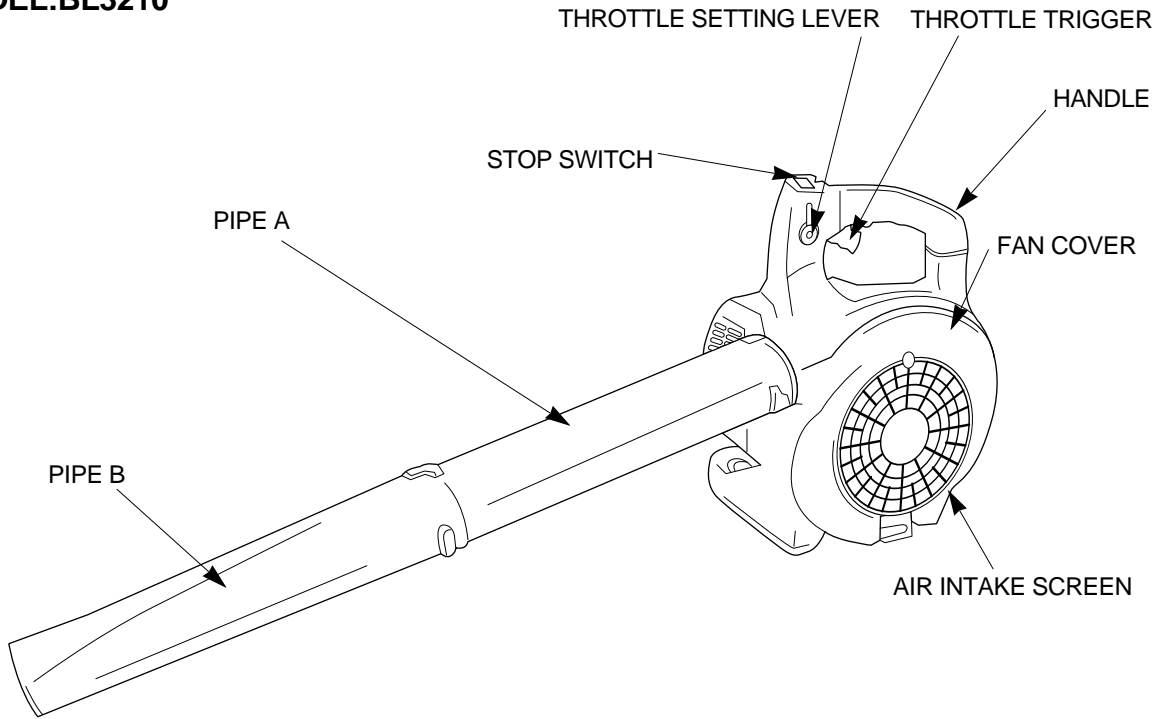

MARKING

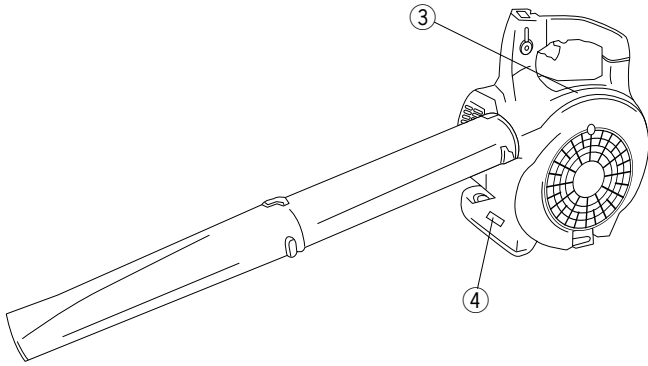

① MODEL NAME

② SERIAL No. (STAMPED)

③



See SYMBOL EXPLANATION

④ SOUND PRESSURE LEVEL



See SYMBOL EXPLANATION

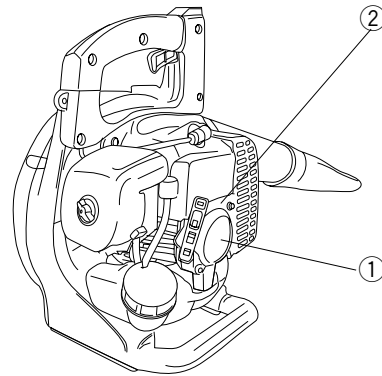

SYMBOL EXPLANATION



Read and understand this Owner's/Operator's Manual before using this product.



Fire Danger: Gasoline is highly flammable. Never add fuel to the Hand-held Blower with a running or hot engine. Do not smoke or place any sources of heat in the vicinity of the fuel.



Breathing exhaust fumes can cause death. Never start or run the engine inside a close room or building.



Hot Surface Warning: Contact may cause burns. During use and for some time after stopping the engine, the engine is very hot. Do not touch engine components such a cylinder, muffler and engine covers until the engine has cooled to ambient temperature.



Always use:

- A protective helmet.
- Ear protection.
- Protective glasses or visor.



Moving parts Warning: Contact with rotation fan or other moving parts could cause serious personal injury or death. Keep hands, feet and clothing away from fan and other moving parts.

SAFETY INSTRUCTIONS

The warning system in This manual identifies potential hazards and has special safety messages that help you and others avoid personal injury, even death.

- **DANGER** , • **WARNING** and • **CAUTION** are signal words to identify the level of hazard.
- **DANGER** : signals an extreme hazard that will cause serious injury or death if the recommended precautions are not followed.
- **WARNING** : signals a hazard that may cause serious injury or death if the recommended precautions are not followed.
- **CAUTION** : signals a hazard that may cause minor or moderate injury if the recommended precautions are not followed. Two other words are also used to highlight information. “Important” calls attention to special mechanical information and “Note” emphasizes general information worthy of special attention.

OPERATOR SAFETY

1. Read and understand this Owner’s/Operator’s Manual before using this product. Be thoroughly familiar with the proper use of this product.
2. Never allow children to operate the Handheld Blower. It is not a toy. Never allow adults to operate the unit without first reading the Operator’s Manual.
3. Always wear eye protection.
4. Wear hearing protection.
5. Always wear sturdy boots with nonslip soles.
6. Always wear heavy long pants, boots and gloves. Do not wear loose clothing, jewelry, short pants, sandals or go barefoot. Secure hair so it is above shoulder length.
7. Always wear a face filter mask.

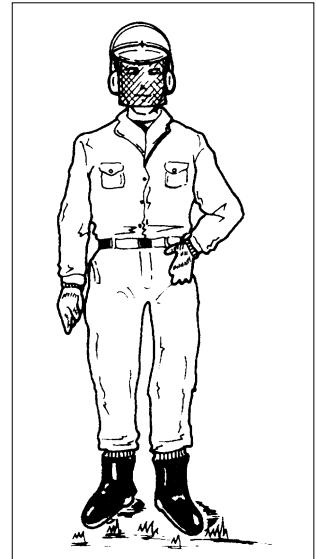

8. Never operate this Handheld Blower when you are tired, ill, under the influence of alcohol, drugs or medication.
9. Never start or run the engine inside a closed room or building. Breathing exhaust fumes can cause death.
10. Keep handles clean of oil, fuel and dirt.

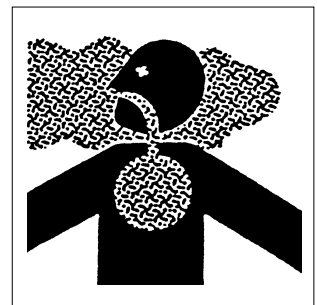

HANDHELD BLOWER SAFETY

1. Make sure the Handheld Blower is correctly assembled as instructed in the Assembly section of this manual.
2. Before each use, inspect the Handheld Blower, replace damaged parts, and check for fuel leaks. Make sure all fasteners are in place and tightened securely.
3. Maintain the Handheld Blower in accordance with the recommended maintenance intervals and procedures detailed in the "Maintenance" section, beginning on page 13.
4. Use the correct accessories. Never use replacement parts that are not approved by Maruyama.
5. Shut off the engine before performing maintenance or working on the machine.
6. If running problems or excessive vibration occur, stop immediately and inspect the unit for the cause. If the cause cannot be determined, or is beyond your ability to correct, return the Handheld Blower to your servicing dealer for repair.

FUEL SAFETY

1. Gasoline is highly flammable and must be handled and stored carefully. Use a container approved for storing gasoline and/or fuel/oil mixture.
2. Mix and pour fuel outdoors and where there are no sparks or flames.
3. Do not smoke near fuel storage containers or the Handheld Blower. Do not smoke while operating the Handheld Blower.
4. Do not overfill the fuel tank. Stop filling 6 ~ 13 mm (1/4 ~ 1/2 inch) from the top of the tank.
5. Wipe up any spilled fuel before starting the engine.
6. Move the Handheld Blower at least 3 m (10ft.) away from the fueling location before starting the engine.
7. Do not remove the fuel tank cap while the engine is running or immediately after stopping the engine.
8. Allow the engine to cool before refueling.
9. Empty the fuel tank before storing the Handheld Blower. Fuel should be emptied after each use as fuel remaining in the tank may leak during storage.
10. Store both fuel and the Handheld Blower away from open flame, sparks and excessive heat. Make sure fuel vapors cannot reach sparks or open flames from heaters, furnaces, electric motors, etc.

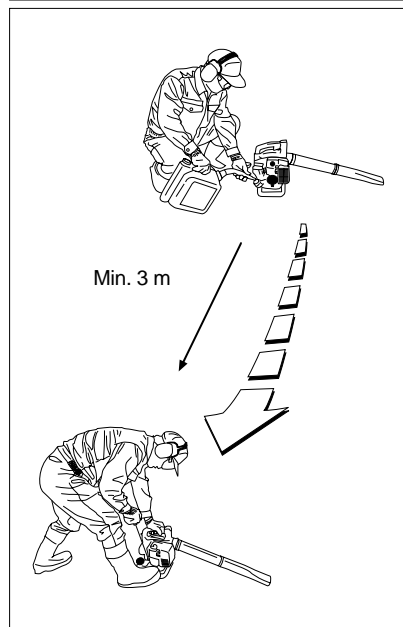
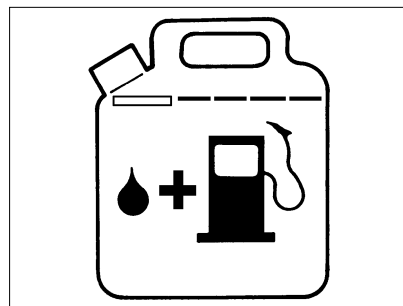

OPERATING SAFETY

1. THIS HANDHELD BLOWER CAN CAUSE SERIOUS INJURIES. Read the instructions carefully. Be familiar with all controls and the proper use of the Handheld Blower.
2. Avoid using the Handheld Blower near rocks, gravel, stones and similar materials which can become dangerous projectiles.
3. Keep children, bystanders and animals outside a 15m (50ft.) radius surrounding the area of operation.
4. If you are approached while operating the Handheld Blower, stop the engine.
5. Never allow children to operate the Handheld Blower.
6. Use the Handheld Blower only in daylight or adequate artificial lighting.
7. Never operate the Handheld Blower without proper guards or other protective safety devices in place.
8. Do not put hands or feet near any moving parts. Keep clear of hot surfaces such as the muffler.
9. Maintain a firm footing while operating the Handheld Blower.
10. Use the right tool for the job. Do not use the Handheld Blower for any job that is not recommended.
11. Know how to stop the machine quickly in an emergency. For information on how to stop the engine refer to the Starting and Stopping Procedures on page 10.
12. Do not point the Handheld Blower nozzle in the direction of people or pets.

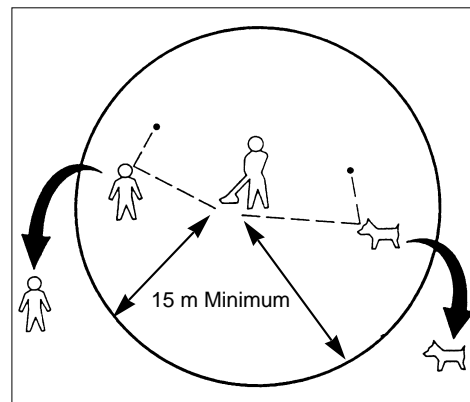

OPERATING TECHNIQUES

1. Operate power equipment only at reasonable hours — not early in the morning or late at night when people may be disturbed. Comply with the times listed in local ordinances. Usual recommendations for hours of operation are 9:00 a.m. to 5:00 p.m., Monday through Saturday.
2. To reduce noise levels, limit the number of pieces of equipment used at any one time and operate power blowers at the lowest possible throttle speed to do the job.
3. Check your equipment before operation, especially the muffler, air intakes and air filters.
4. Use rakes or brooms to loosen debris before blowing.
5. In dusty conditions, slightly dampen surfaces or use a mister attachment when water is available.
6. Conserve water by using power blowers instead of hoses for many lawn and garden applications, including areas such as gutters, screens, patios, grills, porches and gardens.
7. Use the full blower nozzle extension so the air stream can work close to the ground.

8. Watch out for children, pets, open windows, or freshly washed cars and blow debris safely away.
9. After using blowers and other equipment, CLEAN UP! Dispose of debris in trash receptacles.

ASSEMBLY

BLOWER PIPES INSTALLATION

WARNING

Stop the engine before installing or removing blower pipes.

1. Align groove in pipe A with pegs on blower housing and slide pipe A on to housing.
2. Rotate pipes A clock wise to lock it into place.
3. Align groove in pipe B with pegs on pipe A and slide pipe B until proper position.
4. Align groove in pipe B with pegs on pipe A and slide pipe B until proper position.

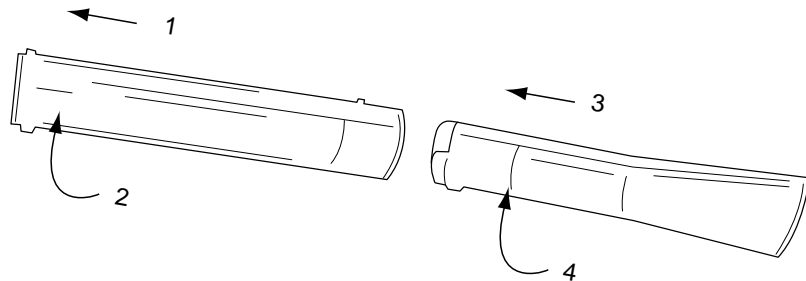
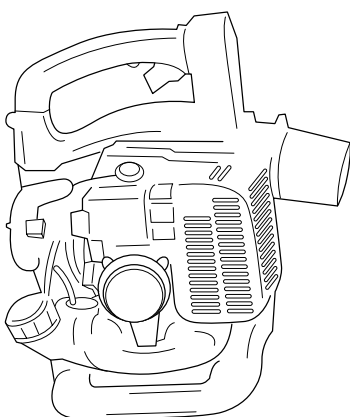
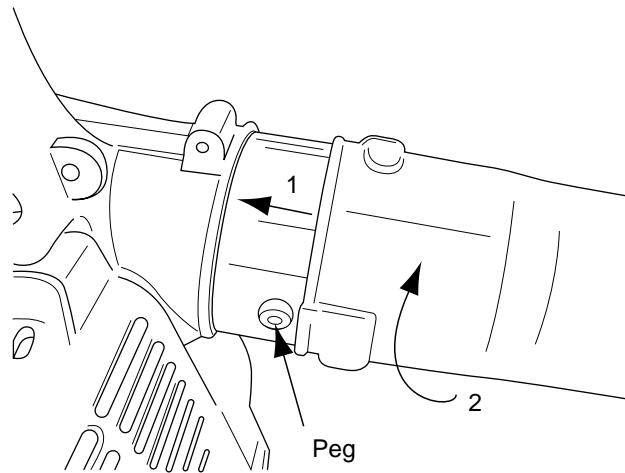

BEFORE OPERATION

FUELING

WARNING! The following precautions will lessen the risk of fire.

WARNING

POTENTIAL HAZARD

- Gasoline contains gasses that can build up pressure inside a gas tank.

WHAT CAN HAPPEN

- Fuel can be sprayed on you when removing fuel tank cap.

HOW TO AVOID THE HAZARD

- Remove fuel tank cap slowly to avoid injury from fuel spray.

DANGER

POTENTIAL HAZARD

- In certain conditions gasoline is extremely flammable and highly explosive.

WHAT CAN HAPPEN

- A fire or explosion from gasoline can burn you, others, and cause property damage.

HOW TO AVOID THE HAZARD

- Use a funnel and fill the fuel tank outdoors, in an open area, when the engine is cold. Wipe up any gasoline that spills.
- Do not fill the fuel tank completely full. Add gasoline to the fuel tank until the level is 6 ~ 13mm (1/4 ~ 1/2 inch) below the bottom of the filler neck. This empty space in the tank allows gasoline to expand.
- Never smoke when handling gasoline, and stay away from an open flame or where gasoline fumes may be ignited by a spark.
- Store gasoline in an approved container and keep it out of the reach of children.
- Never buy more than a 30-day supply of gasoline.

1. Do not smoke near fuel.
2. Mix and pour fuel outdoors and where there are no sparks or flames.
3. Always shut off the engine before refueling. Never remove the fuel tank cap while the engine is running or immediately after stopping the engine.
4. Always open the fuel tank cap slowly to release any possible pressure inside the tank.
5. Do not overfill the fuel tank. Stop filling 6 ~ 13 mm (1/4 ~ 1/2 inch) from the top of the tank.
6. Tighten the tank fuel cap carefully but firmly after refilling.
7. Wipe up any spilled fuel before starting the engine.
8. Move the Handheld Blower at least 3 m (10ft.) away from the fueling location and fuel storage container before starting the engine.

FUEL; MIXING GASOLINE AND OIL

IMPORTANT: The engine used on this Handheld Blower is of a 2-cycle design. The internal moving parts of the engine, i.e., crankshaft bearings, piston pin bearings and piston to cylinder wall contact surfaces, require oil mixed with the gasoline for lubrication. Failure to add oil to the gasoline or failure to mix oil with the gasoline at the appropriate ratio will cause major engine damage which will void your warranty. For your fuel premix, only use a quality oil designed for 2-cycle air-cooled engine.

FUEL MIXTURE: Always use a good quality 2-cycle, air-cooled engine oil mixed at a ratio of 25:1.

FUEL MIXTURE CHART:

2-Cycle Oil (25:1)		
With	1 liter gasoline mix	40 ml oil
	2 liter	80 ml
	5 liter	200 ml

MIXING INSTRUCTIONS: Always mix fuel and oil in a clean container approved for gasoline. Mark the container to identify it as fuel mix for the Handheld Blower. Use regular unleaded gasoline and fill the container with half the required amount of gasoline. Pour the correct amount of oil into the container then add the remaining amount of gasoline. Close the container tightly and shake it momentarily to evenly mix the oil and the gasoline before filling the fuel tank on the Handheld Blower.

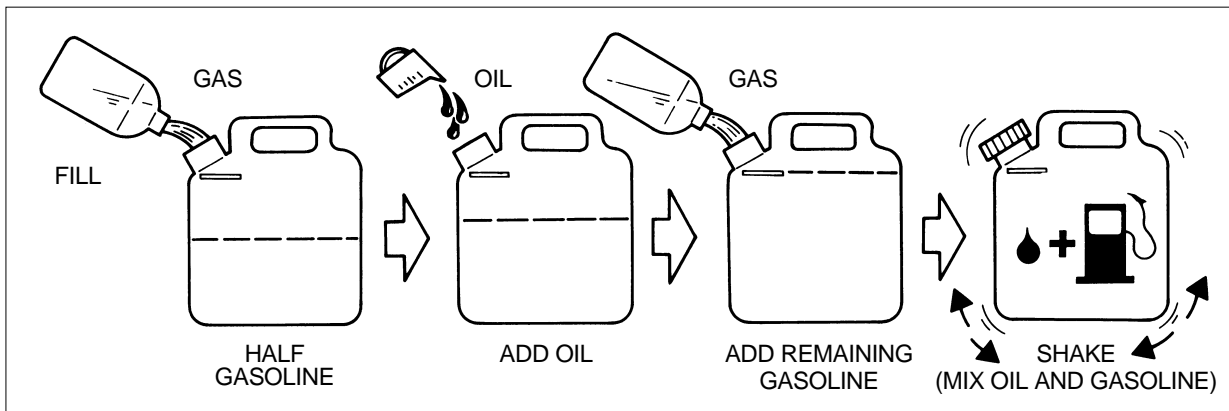

When refilling the Handheld Blower fuel tank, clean around the fuel tank cap to prevent dirt and debris for entering the tank during cap removal. Always shake the premix fuel container momentarily before filling the fuel tank.

Always use a spout or funnel when fueling to reduce fuel spillage. Only fill the tank to within 6 ~ 13 mm (1/4 ~ 1/2 inch) from the top of the tank. Avoid filling to the top of the tank filler neck.

NOTE:

1. Never mix gasoline and oil directly in the Handheld Blower fuel tank.
2. Do not use National Marine Manufacturer's Association (NMMA) or BIA certified oils. This type of 2-cycle engine oil does not have the proper additives for air-cooled, 2-cycle engines and can cause engine damages.
3. Do not use automotive motor oil. This type of oil does not have the proper additives for air-cooled, 2-cycle engines and can cause engine damage.

STARTING AND STOPPING PROCEDURE

BEFORE STARTING THE ENGINE: Fill the fuel tank as instructed in the BEFORE OPERATION section of this manual (page8). Rest the Handheld Blower on the ground. Make sure that the area is clear of any broken glass, nails, wire, rocks or other debris. Keep all bystanders, children and animals away from the working area.

COLD STARTING PROCEDURE

This Blower is equipped with a fuel primer and a choke system. To start a “cold” engine properly, perform the following procedure:

1. Pump the primer bulb at the bottom of the carburetor until fuel can be seen flowing through the fuel return line to the fuel tank. (Flowing fuel should be almost clear, not foamy or full of bubbles.)
2. Move the choke lever to the closed (\perp) position.

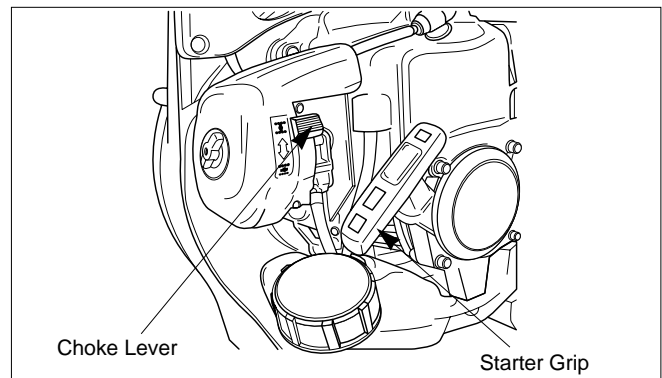
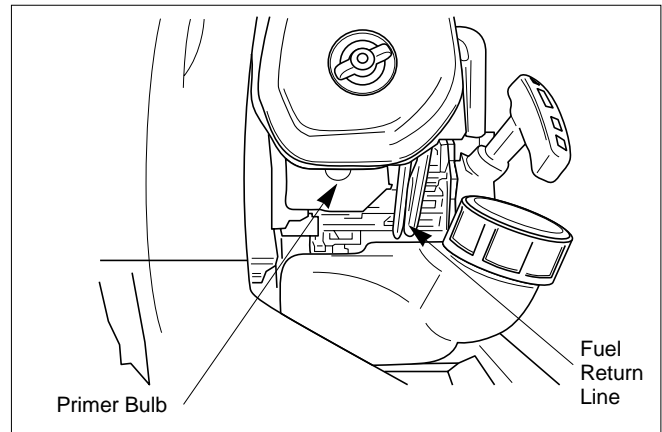

3. Move the stop switch to the “ON” position.

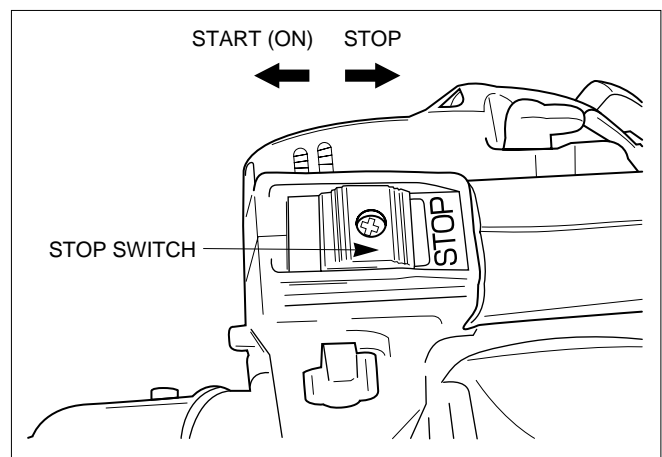

4. (1) Press the throttle trigger
(2) Move the throttle setting lever to half position.
(3) Release the throttle trigger.
(4) Release the throttle setting lever.
(Throttle is kept in half position.)

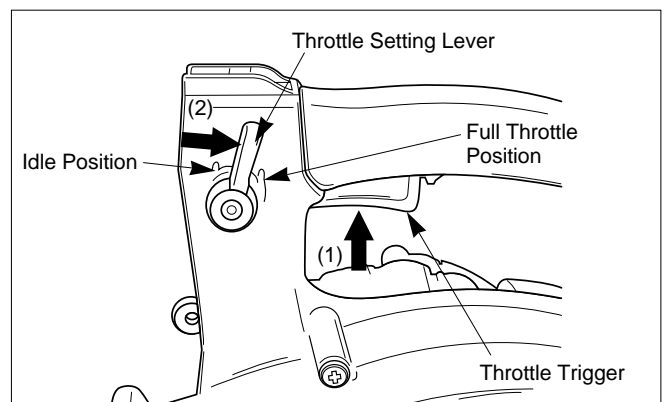

5. Hold the Handheld Blower with your left hand and press it down firmly. Hold the assist handle with your right foot gently.

IMPORTANT: Be careful not make damages to fuel tank or the blower by your foot.

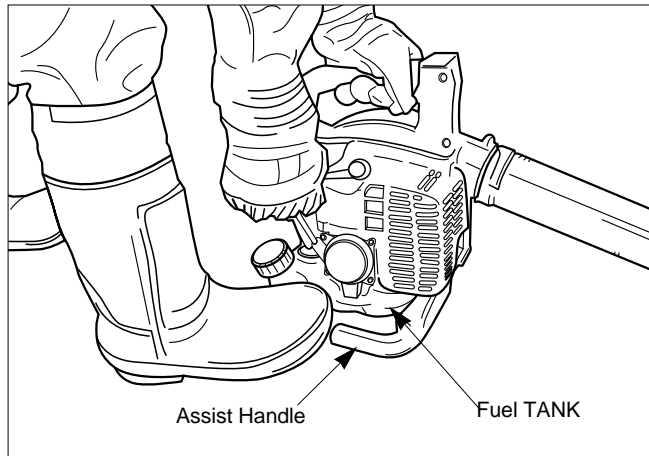

6. Pull the starter grip. Grasping the starter grip, slowly pull the starter cord out until you feel resistance, then pull the cord quickly and powerfully. Pull the starter grip until the engine starts.

7. After the engine starts, move the throttle setting lever to the idle position, then move the choke lever to the open ($\overline{\text{---}}$) position.

If the engine stops running before you move the choke lever to the open ($\overline{\text{---}}$) position:

- A. Go ahead and open the choke.
- B. Make sure the throttle setting lever is set to the idle position.
- C. Pull the starter grip until the engine starts.

HOT RESTART

To start the engine that is already warmed up (hot restart), or if the ambient temperature exceeds 20°C:

1. Pump the primer bulb at the bottom of the carburetor until fuel can be seen flowing through the fuel return line to the fuel tank.
2. Move the choke lever to the ($\overline{\text{---}}$) position and move the stop switch to the "ON" position.
3. Move the throttle setting lever to the idle position and pull the starter grip.
4. If the engine fails to start after three to four pulls, follow the instruction in the Cold Starting Procedure section (page10).

If the engine fails to start after you follow the above procedures, contact an authorized Maruyama dealer.

- NOTE: 1. Don't pull the starter cord out completely.**
2. Do not release the starter cord from the fully extended position.

TO STOP THE ENGINE

1. Move the throttle setting lever to the idle position. Release the throttle trigger.
2. Slide the stop switch to the "STOP" position.

CARBURETOR ADJUSTMENT

This Handheld Blower is equipped with non-adjustable fuel mixture carburetor. The engine idle speed is the only adjustment for the operator.

⚠ WARNING

- Idle speed adjustment should be checked each time the unit is operated.

⚠ WARNING

POTENTIAL HAZARD

- Engine must be running to make carburetor adjustments.
- When engine is running, fan is rotating and other parts are moving.

WHAT CAN HAPPEN

- Contact with rotating fan or other moving parts could cause serious personal injury or death.

HOW TO AVOID THE HAZARD

- Keep hands, feet and clothing away from fan and other moving parts.
- Keep all bystanders and pets away from unit while making carburetor adjustments.

Wear the recommended personal protective equipment and observe all safety instructions.

Engine Idle Speed:

When the throttle trigger and the throttle setting lever is idle position the engine should return to an idle speed between 2700 and 3300 RPM. The engine should not stall (stop running) at engine idle speed.

To adjust the engine idle speed, rotate the idle speed adjustment screw on the carburetor.

- Turn the idle speed screw in (clockwise) to increase the engine idle speed.
- Turn the screw out (counterclockwise) to decrease the engine idle speed.

If idle speed adjustment is necessary, and after adjustment the engine stalls, stop using the Handheld Blower immediately!

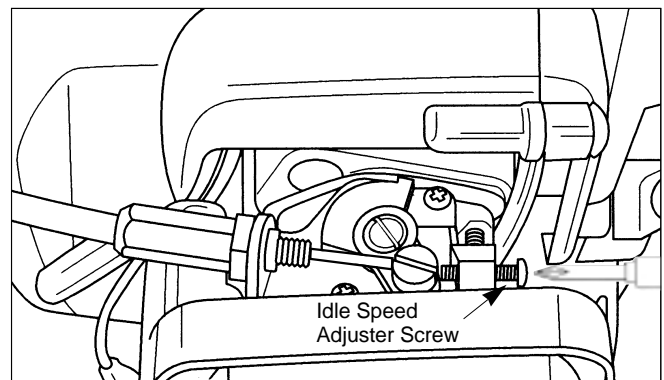

Contact your local authorized Maruyama Dealer for assistance and servicing.

OPERATION THE HANDHELD BLOWER

WARNING

- Always wear eye protection, hearing protection, gloves, face filter mask and sturdy boots with nonslip soles when operating the Handheld Blower.

1. Allow the engine to warm up for a few minutes.
2. Control engine speed by the throttle trigger, or set the engine speed by the throttle setting lever.

*To adjust the throttle setting lever.

Press the throttle trigger, then adjust the throttle setting lever as you wish operation.

3. Operate lower speed to blow leaves or debris ground.
4. If the blow is not enough to blow, open the throttle gradually.

NOTE: Operate Handheld Blower at the lowest throttle setting to do the job.

REGULAR MAINTENANCE

Maintenance, replacement or repair of emission control devices and systems may be performed by any repair establishment or individual; however, warranty repairs must be performed by a dealer or service center authorized by Maruyama. The use of parts that are not equivalent in performance and durability to authorized parts may impair the effectiveness of the emission control system and may have a bearing on the outcome of a warranty claim.

WARNING

- Stop the engine before performing maintenance.

AIR FILTER

Maintenance Interval

- The air filter should be cleaned and inspected each time the Handheld Blower is used, or more often when working in extremely dusty conditions.
- Replace after every 100 hours of operation.

Air Filter Cleaning

1. Move the choke lever to the closed()position.
2. Loosen the knob and remove the air cleaner cover.
3. Remove the foam element and filter screen from the air cleaner body.

4. Clean the foam element and filter screen with air blow or warm soapy water.
5. Reassemble the filter screen and foam element to the air cleaner body. Foam element must be located as the felt side face to the cleaner cover.
6. Reinstall the air cleaner cover and tighten the knob.

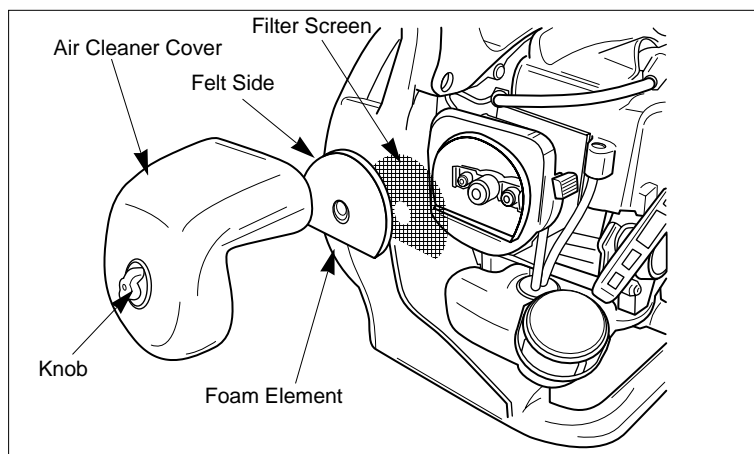

FUEL FILTER

Maintenance Interval

- The fuel filter should be cleaned and inspected for damage after each 20 hours of operation.
- The fuel filter should be replaced after every 100 hours of operation.

Fuel Filter Replacement

The fuel filter is attached to the end of the fuel pick-up hose inside the fuel tank.

To replace the fuel filter:

1. Make sure the fuel tank is empty.
2. Remove the fuel cap.
3. Using a wire hook, gently pull the fuel filter out through the fuel filler opening.
4. Grasp the fuel hose next to the fuel filter fitting and remove the filter, but do not release the hose.
5. While still holding on to the fuel hose, attach the new fuel filter.
6. Drop the new fuel filter back into the fuel tank.
7. Make sure that the fuel filter is not stuck in a corner of the tank, and that the fuel hose is not doubled over (kinked) before refueling.

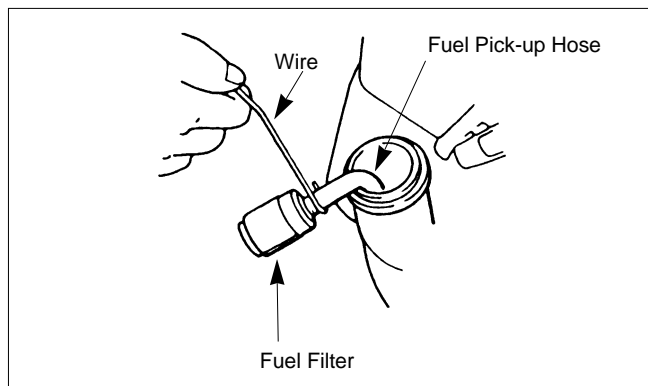

SPARK PLUG

Maintenance Interval

- The spark plug should be removed from the engine and checked after each 25 hours of operation.
- Replace the spark plug after every 100 hours of operation.

Spark Plug Maintenance

1. With the engine at ambient (room) temperature, twist the high tension lead boot on the spark plug back and forth a couple of times to loosen the boot, then pull the boot off of the spark plug.
2. Remove the spark plug.
3. Clean the electrodes with a stiff brush.
4. Adjust the electrode air gap to 0.6- 0.7 mm (024-.028 in).
5. Replace the spark plug if it is oil-fouled, damaged, or if the electrodes are worn down.
6. Do not overtighten the spark plug when installing. The tightening torque is 10.7-16.6 N-m (95-148 in. lbs).

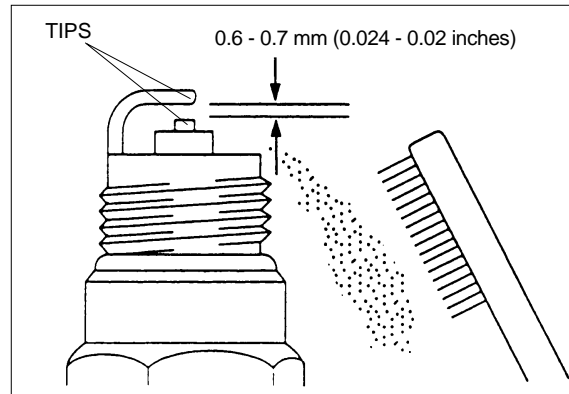

CYLINDER COOLING FINS

Maintenance Interval

- The cylinder cooling fins should be cleaned after every 25 hours of operation, or once a week, whichever comes first.
- Air must flow freely around and through the cylinder cooling fins to prevent engine overheating. Leaves, grass, dirt and debris buildup on the fins will increase the operating temperature of the engine, which can reduce engine performance and shorten engine life.

Cooling Fin Cleaning

1. With the engine at ambient (room) temperature, loosen the knob and remove the air cleaner cover.
2. Twist the high tension lead boot on the spark plug back and forth a couple of times to loosen the boot, then pull the boot off of the spark plug.
3. Remove the four screws retaining the topcover, then remove the topcover.
4. Clean all dirt and debris from the cooling fins and from around the cylinder base.
5. Reinstall the topcover and the cleaner cover.

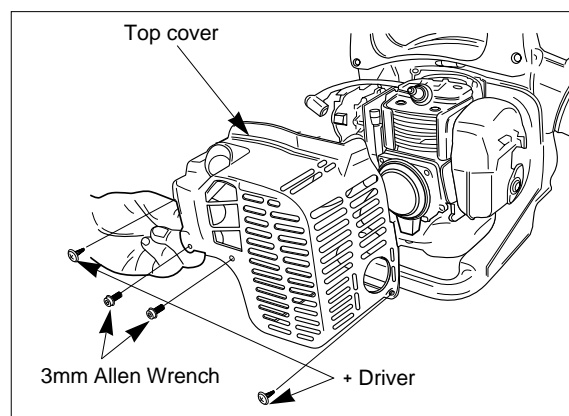
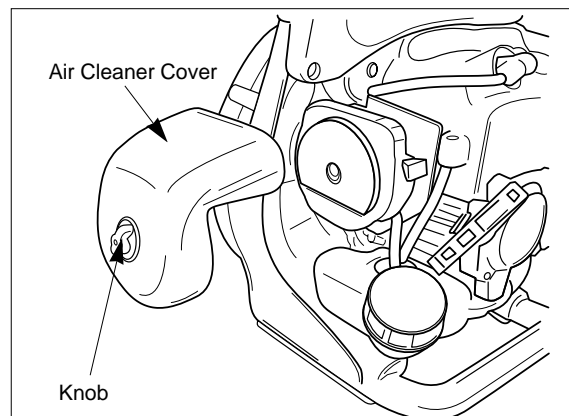

ENGINE SCREEN

Maintenance Interval

The screen should be cleaned and inspected each time the Handheld Blower is used.

Screen Cleaning

Clean all dirt and debris from the screen.

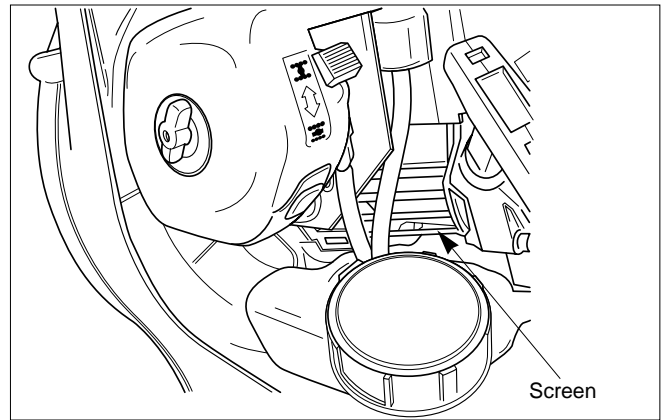

SPARK ARRESTER

⚠ WARNING

POTENTIAL HAZARD

- Muffler surface becomes hot when Handheld Blower is in operation and remains hot for some time after the engine is shut off.

WHAT CAN HAPPEN

- Contact with hot muffler surfaces could cause a burn.

HOW TO AVOID THE HAZARD

- Make sure the muffler is cool before inspecting and cleaning the spark arrester.

Maintenance Interval

- The spark arrester should be inspected and cleaned after every 25 hours of use.
- Replace the screen if it cannot be thoroughly cleaned, or if it is damaged.

Spark Arrester Maintenance

1. With the engine at ambient (room) temperature, loosen the knob and remove the air cleaner cover (See cooling fin cleaning.).
2. Twist the high tension lead boot on the spark plug back and forth a couple of times to loosen the boot, then pull the boot off of the spark plug.
3. Remove the four screws retaining the topcover, then remove the topcover (see Cooling fin cleaning).
4. Remove the two screws retaining the muffler.
5. Remove and clean the tail, gasket and spark arrester with a safety solvent and a stiff brush. If any part cannot be thoroughly cleaned, it must be replaced.

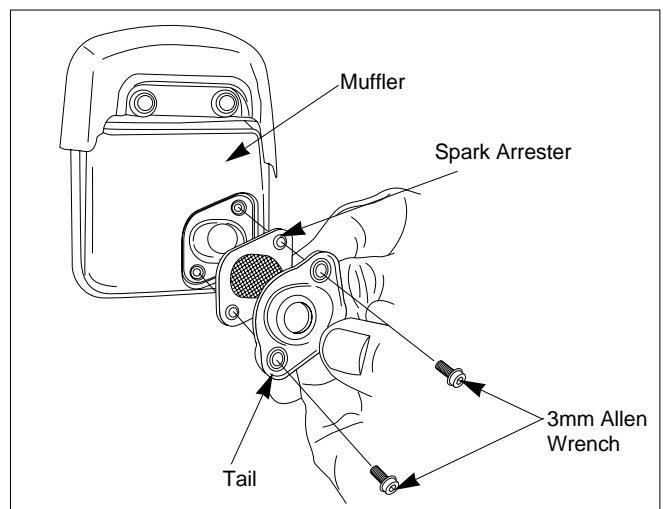

- Reinstall the spark arrester and tail onto the muffler, then reinstall and tighten the two screws. The hole of tail must be located in left (refer to the picture.)
- Reinstall the topcover and the cleaner cover.

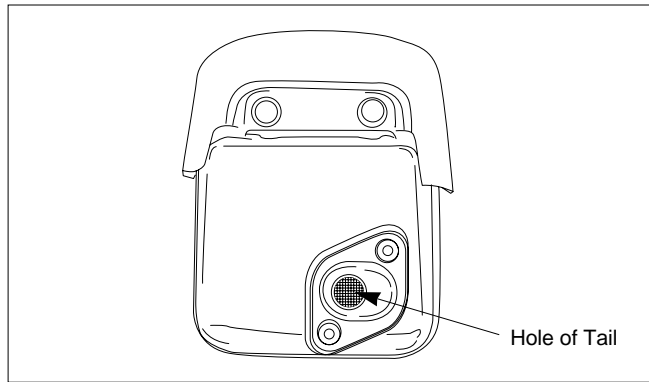

EXHAUST MUFFLER

Maintenance Interval

The muffler should be inspected and cleaned after each 100 hours of use.

Muffler Maintenance

- With the engine at ambient (room) temperature, loosen the knob and remove the air cleaner cover (See cooling fin cleaning.).
- Twist the high tension lead boot on spark plug back and forth a couple of times to loosen the boot, then pull the boot of the spark plug.
- Remove the four screws, and remove the topcover (see Cooling fin cleaning).
- Remove the spark arrester (see spark arrester maintenance). Clean the muffler with a stiff brush.

IMPORTANT: Be careful not to allow any dirt or debris to fall into the exhaust port, as this can cause engine damage.

- Reinstall the spark arrester and tail onto the muffler, then reinstall and tighten the two screws. The hole of tail must be located in left. (see spark arrester maintenance)
- Reinstall the top cover and the cleaner cover.

AIR INTAKE SCREEN

Maintenance Interval

The air intake screen should be cleaned and inspected each time Handheld Blower is used and when air flow dropped down during operation.

Air Intake Screen Cleaning

Clean all dirt and debris from the air intake screen.

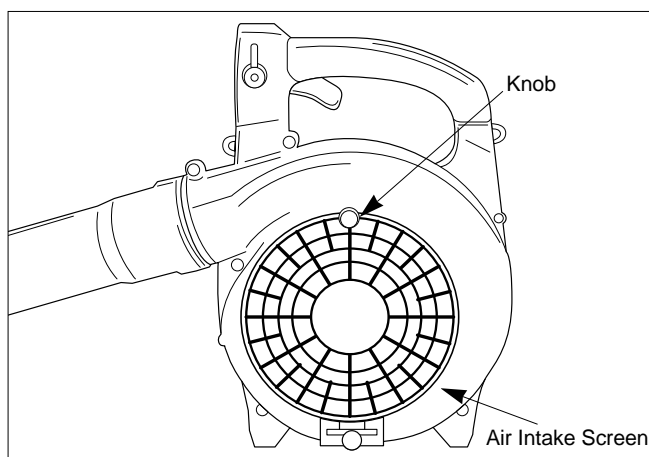

WARNING

- Never use the handheld Blower without the air intake screen. Before starting the engine, check the knob is securely tightened and no damage.

GENERAL CLEANING AND TIGHTENING

⚠ WARNING

POTENTIAL HAZARD

- When engine is running, fan is rotating and other parts are moving.

WHAT CAN HAPPEN

- Contact with rotating fan or other moving parts could cause serious personal injury or death.

HOW TO AVOID THE HAZARD

- Always turn off your Handheld Blower before you clean or perform any maintenance on it.

The Maruyama Handheld Blower will provide maximum performance for many, many hours if it is maintained properly. Good maintenance includes regular checking of all fasteners for correct tightness, and cleaning the entire machine.

STORAGE

For long term storage of the Handheld Blower:

1. Empty the fuel tank into a suitable fuel storage container approved for gasoline.
2. Pump the primer bulb on the carburetor until all fuel is discharged through the clear fuel return hose.
3. Run the engine to remove any fuel that may remain in the carburetor.
4. Perform all regular maintenance procedures and any needed repairs.
5. Remove the spark plug and squirt a very small amount of oil into the cylinder.
6. Pull the starter grip once.
7. Slowly pull the starter grip to bring the piston to the top of the cylinder (TDC).
8. Reinstall the spark plug.
9. Store the Handheld Blower in a dry place away from excessive heat, sparks or open flame.

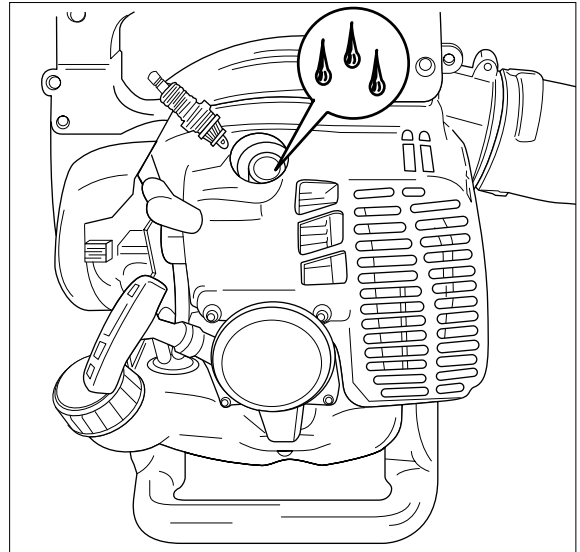

⚠ CAUTION

POTENTIAL HAZARD

- Oil may squirt out of the spark plug opening when you pull the starter grip.

WHAT CAN HAPPEN

- Oil can cause eye injuries.

HOW TO AVOID THE HAZARD

- Protect your eyes and keep your face away from the spark plug opening.

TROUBLESHOOTING

Problem	Cause	Action
Engine Will Not Start	STOP switch set to off position Empty fuel tank Primer bulb wasn't pushed enough Engine flooded	Move switch to on position Fill fuel tank Press primer bulb until fuel flows through fuel return line Use warm engine starting procedure
Engine Lacks Power or dropped down when blowing.	Dirty air filter Clogged spark arrester or exhaust port. Blower pipes clogged, loos or damaged.	Clean or replace air filter Clean spark arrester or exhaust port. Unclog or tighten or replace

If further assistance is required, contact your local authorized Maruyama service dealer.

MAINTENANCE PERIOD

		Every	Every	Every	
	Maintenance	Daily	20 hours	50 hours	100 hours
	Check and replenish fuel	●			
	Check for fuel leakage	●			
	Check bolts, nuts and screws for tightness or missing	●			
	Check engine idle speed adjustment	●			
■	Clean air filter element		●		
■	Remove dust and dirt from engine screen		●		
■	Remove dust and dirt from air intake screen		●		
	Tighten bolts and nuts			●	
	Clean spark plug and adjust electrode gap			●	
■	Remove dust and dirt from cylinder fins			●	
●	Remove carbon deposits in exhaust port			●	
●	Clean spark arrester			●	
	Replace fuel filter				●
●	Remove carbon deposits on piston head and combustion chamber				●
●	Remove carbon deposits in transfer ports				●
	Replace fuel tube, fuel tank cap gasket	It is recommended to replace every 3 years			

●: Service to be performed by an authorized Maruyama service dealer.

■: Service more frequently under dusty conditions.

NOTE:

The service intervals indicated are to be used as a guide.

Service to be performed more frequently as necessary depending on operating condition.

